



Remote Monitoring for Business



Wireless Water Rope Sensors

General Description

The [ALTA Wireless Water Rope Sensor](#) detects the presence of water anywhere along the surface of the rope. Sensor comes with 10 feet of water rope. Additional 10 ft sections are available and can be connected up to 100 feet.

- 10 ft lead and 10 ft water detection rope
- Immediately detects water anywhere along rope
- Expandable up to 100 ft of detection rope

Principle of Operation

The ALTA Wireless Water Rope Sensor detects conductive liquids anywhere along the length of the detection rope by using two wires covered with conducting polymer. When water or conductive liquid contacts the rope, the sensor will immediately turn on the RF radio and transmit the data to the wireless gateway and iMonnit Online Sensor Monitoring and Notification System, allowing the user to immediately receive an alert by SMS text, email or voice call. The sensor rope dries quickly allowing the sensor to reset for next use. Detection rope can be expanded up to 100 feet by simply clicking additional 10 foot sections of detection rope together. Additional sections of water detection rope are available on the Monnit website.

Example Applications

- Data center and server room water monitoring
- Document retention center monitoring
- Basement water monitoring
- Plumbing leak detection
- Boat bilge monitoring
- Storage monitoring
- [Additional applications](#)

Features of Monnit ALTA Sensors

- Wireless range of 1,200+ feet through 12+ walls *
- Frequency-Hopping Spread Spectrum (FHSS)
- Improved interference immunity
- Improved power management for longer battery life **
- Encrypt-RF® Security (Diffie-Hellman Key Exchange + AES-128 CBC for sensor data messages)
- All ALTA sensors now have up to 3200 readings:
 - 10-minute heartbeats = 22 days
 - 2-hour heartbeats = 266 days
- Over-the-air updates (future proof)
- Free iMonnit basic online wireless sensor monitoring and notification system to configure sensors, view data and set alerts via SMS text and email



*Actual range may vary depending on environment.

**Battery life is determined by sensor reporting frequency and other variables. Other power options are also available.

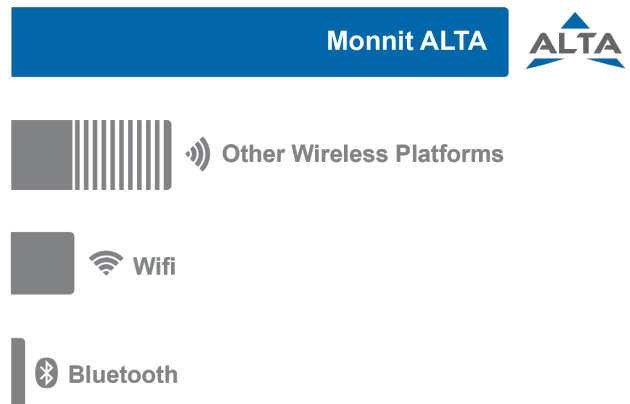
Wireless Range Comparison

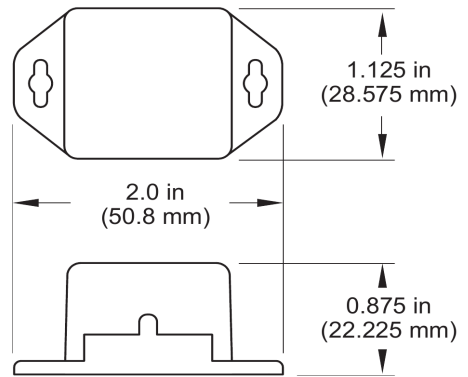



ALTA Commercial Coin Cell Wireless Water Rope Sensor Technical Specifications	
Supply voltage	2.0–3.8 VDC *
Current consumption	0.2 μ A (sleep mode), 0.7 μ A (RTC sleep), 570 μ A (MCU idle), 2.5 mA (MCU active), 5.5 mA (radio RX mode), 22.6 mA (radio TX mode)
Operating temperature range (board circuitry and coin cell)	-7°C to +60°C (20°F to +140°F) **
Optimal battery temperature range (coin cell)	+10°C to +50°C (+50°F to +122°F)
Water rope material	PE + alloy lead
Water rope maximum exposed temperature	75°C (167°F)
Water rope weight	30g/meter
Water rope pull force limit	60kg
Water rope core resistance	3ohm/100 meters
Water rope cable diameter	5.5mm
Water rope cable length	10 ft (120 in) included (expandable to 100 ft)
Water rope fire resistance	Second pressure plenum cable
Integrated memory	Up to 3200 sensor messages
Wireless range	1,200+ ft non-line-of-sight
Security	Encrypt-RF® (256-bit key exchange and AES-128 CTR)
Sensor Weight	0.7 ounces
Certifications	<div style="display: flex; align-items: center; gap: 10px;">   Industry Canada </div> 900 MHz product; FCC ID: ZTL-G2SC1 and IC: 9794A-G2SC1. 868 and 433 MHz product tested and found to comply with: EN 300 220-2 V3.1.1 (2017-02), EN 300 220-2 V3.1.1 (2017-02) and EN 60950



* Hardware cannot withstand negative voltage. Please take care when connecting a power device.

** At temperatures above 100°C, it is possible for the board circuitry to lose programmed memory.

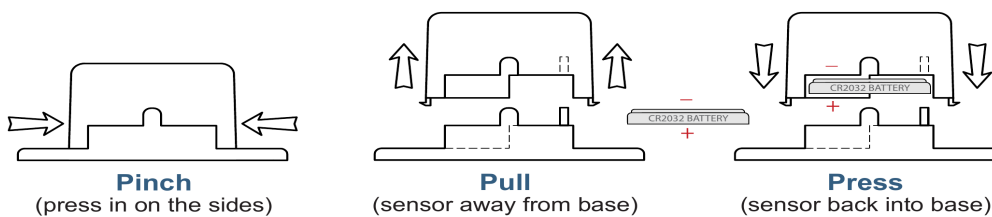
PinchPower™ Enclosures

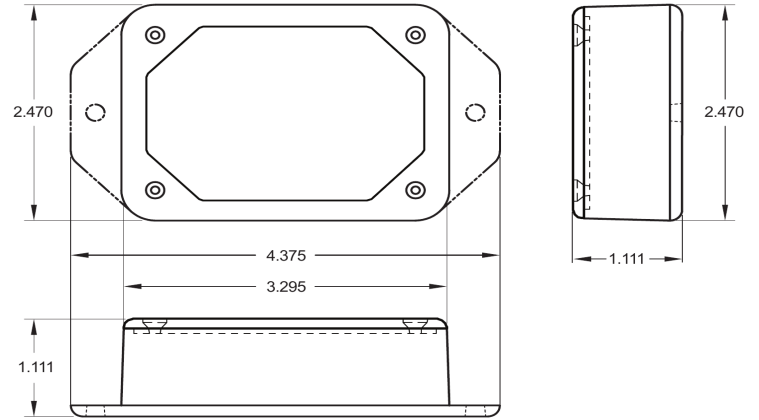



ALTA Commercial AA Wireless Water Rope Sensor Technical Specifications	
Supply voltage	2.0–3.8 VDC (3.0–3.8 VDC using power supply) *
Current consumption	0.2 μ A (sleep mode), 0.7 μ A (RTC sleep), 570 μ A (MCU idle), 2.5 mA (MCU active), 5.5 mA (radio RX mode), 22.6 mA (radio TX mode)
Operating temperature range (board circuitry and batteries)	-18°C to 55°C (0°F to 130°F) using alkaline -40°C to 85°C (-40°F to 185°F) using lithium **
Optimal battery temperature range (AA)	+10°C to +50°C (+50°F to +122°F)
Water rope material	PE + alloy lead
Water rope maximum exposed temperature	75°C (167°F)
Water rope weight	30g/meter
Water rope pull force limit	60kg
Water rope core resistance	3ohm/100 meters
Water rope cable diameter	5.5mm
Water rope cable length	10 ft (120 in) included (expandable to 100 ft)
Water rope fire resistance	Second pressure plenum cable
Integrated memory	Up to 3200 sensor messages
Wireless range	1,200+ ft non-line-of-sight
Security	Encrypt-RF® (256-bit key exchange and AES-128 CTR)
Weight	3.7 ounces
Certifications	<div style="display: flex; align-items: center; gap: 10px;">   Industry Canada </div> 900 MHz product; FCC ID: ZTL-G2SC1 and IC: 9794A-G2SC1. 868 and 433 MHz product tested and found to comply with: EN 300 220-2 V3.1.1 (2017-02), EN 300 220-2 V3.1.1 (2017-02) and EN 60950

* Hardware cannot withstand negative voltage. Please take care when connecting a power device.

** At temperatures above 100°C, it is possible for the board circuitry to lose programmed memory.



Power Options

The standard version of this sensor is powered by two replaceable 1.5 V AA sized batteries (included with purchase).

This sensor is also available with a line power option. The line powered version of this sensor has a barrel power connector allowing it to be powered by a standard 3.0–3.6 V power supply. The line powered version also uses two standard 1.5 V AA batteries as backup for uninterrupted operation in the event of line power outage.

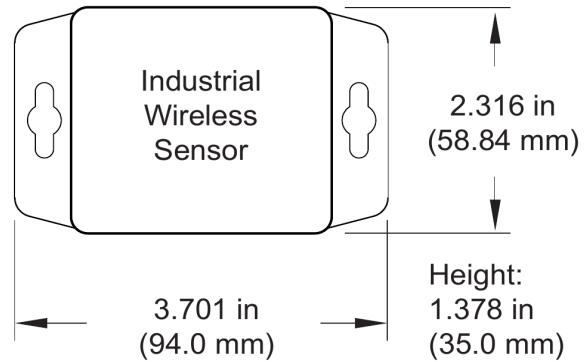
Power options must be selected at time of purchase, as the internal hardware of the sensor must be changed to support the selected power requirements.



ALTA Industrial Wireless Water Rope Sensor Technical Specifications		
Supply voltage		2.0–3.8 VDC (3.0–3.8 VDC using power supply) *
Current consumption		0.2 μ A (sleep mode), 0.7 μ A (RTC sleep), 570 μ A (MCU idle), 2.5 mA (MCU active), 5.5 mA (radio RX mode), 22.6 mA (radio TX mode)
Operating temperature range (board circuitry and battery)		-40°C to +85°C (-40°F to +185°F) **
Included battery	Max temperature range	-40° to +85°C (-40° to +185°F)
	Capacity	1500 mAh
Optional solar feature	Solar panel	5VDC/30mA (53mm x 30mm)
	Charging temperature range	0° to 45°C (32° to 113°F)
	Max temperature range	-20° to 60°C (-4° to 140°F)
	Included rechargeable battery	600 mAh/>2000 charge cycles (80% of initial capacity)
	Solar efficiency	Optimized for high and low-light operation ***
Water rope material		PE + alloy lead
Water rope maximum exposed temperature		75°C (167°F)
Water rope weight		30g/meter
Water rope pull force limit		60kg
Water rope core resistance		3ohm/100 meters
Water rope cable diameter		5.5mm
Water rope cable length		10 ft (120 in) included (expandable to 100 ft)
Water rope fire resistance		Second pressure plenum cable
Integrated memory		Up to 3200 sensor messages
Wireless range		1,200+ ft non-line-of-sight
Security		Encrypt-RF® (256-bit key exchange and AES-128 CTR)
Weight		4.7 ounces
Enclosure rating		NEMA 1, 2, 4, 4x, 12 and 13 rated, sealed and weather proof
UL rating		UL Listed to UL508-4x specifications (File E194432)
Certifications	 	900 MHz product; FCC ID: ZTL-G2SC1 and IC: 9794A-G2SC1. 868 and 433 MHz product tested and found to comply with: EN 300 220-2 V3.1.1 (2017-02), EN 300 220-2 V3.1.1 (2017-02) and EN 60950

* Hardware cannot withstand negative voltage. Please take care when connecting a power device.

** At temperatures above 100°C, it is possible for the board circuitry to lose programmed memory.

*** Light present 25% of day yields 125% of operating power to support 10-minute heartbeats.

Commercial Grade Sensors

Monnit commercial grade sensors are designed for applications in ordinary environments (normal room temperature, humidity and atmospheric pressure). Do not use these sensors under the following conditions as these factors can deteriorate the product characteristics and cause failures and burnout.

- Corrosive gas or deoxidizing gas: chlorine gas, hydrogen sulfide gas, ammonia gas, sulfuric acid gas, nitric oxides gas, etc.
- Volatile or flammable gas
- Dusty conditions
- Low-pressure or high-pressure environments
- Wet or excessively humid locations
- Places with salt water, oils chemical liquids or organic solvents
- Where there are excessively strong vibrations
- Other places where similar hazardous conditions exist

Use these products within the specified temperature range. Higher temperature may cause deterioration of the characteristics or the material quality.

Industrial Grade Sensors | Type 1, 2, 4, 4X, 12 and 13 NEMA Rated Enclosure

Monnit's Industrial sensors are enclosed in reliable, weatherproof NEMA rated enclosures. Our NEMA-rated enclosures are constructed for both indoor or outdoor use and protect the sensor circuitry against the ingress of solid foreign objects like dust as well as the damaging effects of water (rain, sleet, snow, splashing water, and hose-directed water).

- Safe from falling dirt
- Protects against wind-blown dust
- Protects against rain, sleet, snow, splashing water, and hose-directed water
- Increased level of corrosion resistance
- Will remain undamaged by ice formation on the enclosure



Monnit Corporation

3400 South West Temple • Salt Lake City, UT 84115 • 801-561-5555
www.monnit.com